

**SURVEYOR'S CERTIFICATE**  
 I, K. GREG HANSEN, DO HEREBY CERTIFY THAT I AM A REGISTERED PROFESSIONAL LAND SURVEYOR IN THE STATE OF UTAH IN ACCORDANCE WITH TITLE 58, CHAPTER 22, PROFESSIONAL ENGINEERS AND LAND SURVEYORS ACT AND THAT I HOLD CERTIFICATE NO. 167819 AS PRESCRIBED BY THE LAWS OF THE STATE OF UTAH AND THAT THIS IS A TRUE AND ACCURATE MAP OF THE TRACT OF LAND TO BE ANNEXED TO NORTH OGDEN CITY, WEBER COUNTY, UTAH.

**ANNEXATION BOUNDARY DESCRIPTION**  
 A TRACT OF LAND SITUATED IN THE NORTHEAST QUARTER AND SOUTHEAST QUARTER OF SECTION 27, TOWNSHIP 7 NORTH, RANGE 1 WEST, SALT LAKE BASE AND MERIDIAN, U.S. SURVEY, MORE PARTICULARLY DESCRIBED AS FOLLOWS.

BEGINNING AT THE SOUTHEAST CORNER OF CAMARREN COVE ESTATES SUBDIVISION PHASE 3, NORTH OGDEN, WEBER COUNTY, UTAH SURVEY ALSO BEING A POINT ON THE NORTH OGDEN CITY CORPORATE BOUNDARY LINE SAID POINT ALSO DESCRIBED OF RECORD AS BEING THE SOUTHEAST CORNER OF THE NORTHWEST QUARTER OF SAID SECTION 27 BEING LOCATED NORTH 00°30'30" EAST 2642.76 FEET ALONG THE WEST LINE OF SAID SECTION 27 AND SOUTH 89°17'22" EAST 2645.94 FEET FROM THE SOUTHWEST CORNER OF SAID SECTION 27; RUNNING THENCE NORTH 00°35'23" EAST 50.00 FEET ALONG SAID EAST BOUNDARY LINE OF CAMARREN COVE ESTATES SUBDIVISION PHASE 3 AND SAID NORTH OGDEN CITY CORPORATE BOUNDARY LINE TO THE SOUTHWEST CORNER OF HALL BROTHERS LAND CO. LLC PROPERTY TAX ID PARCEL NUMBER 160490083 ENTRY NO. 1707971 IN BOOK 2074 AT PAGE 824 AS DESCRIBED IN THE RECORDS OF THE WEBER COUNTY RECORDER; THENCE EAST 510.49 FEET MORE OR LESS ALONG SAID SOUTH BOUNDARY LINE; THENCE SOUTH 00°27'37" WEST 244.29 FEET MORE OR LESS TO THE NORTHEAST CORNER OF HALL BROTHERS LAND CO. LLC PROPERTY TAX ID PARCEL NUMBER 160490113 ENTRY NO. 1707971 IN BOOK 2074 AT PAGE 824 AS DESCRIBED IN THE RECORDS OF THE WEBER COUNTY RECORDER BEING A POINT ON SAID NORTH OGDEN CITY CORPORATE BOUNDARY LINE; THENCE ALONG SAID HALL BROTHERS PROPERTY AND SAID NORTH OGDEN CITY CORPORATE BOUNDARY LINE THE FOLLOWING TWO (2) COURSES; (1) NORTH 89°32'23" WEST 511.02 FEET; AND (2) NORTH 00°35'23" EAST 190.19 TO THE POINT OF BEGINNING. CONTAINING 2.84 ACRES.

THE BASIS OF BEARINGS FOR THIS PLAT IS THE WEST LINE OF SECTION 27, TOWNSHIP 7 NORTH, RANGE 1 WEST, SALT LAKE BASE AND MERIDIAN WHICH BEARS NORTH 00°30'30" WEST (UTAH NORTH NAD 83 STATE PLANE GRID BEARING BEARS NORTH 00°51'54" WEST FROM THE SOUTHWEST CORNER TO THE NORTHWEST CORNER OF SAID SECTION 27).

SIGNATURE \_\_\_\_\_ DATE \_\_\_\_\_

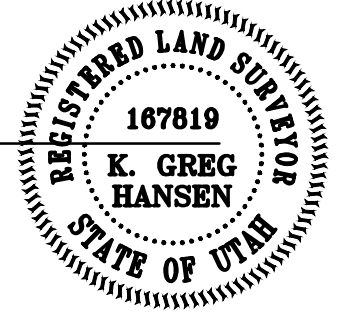

**ACCEPTANCE BY LEGISLATIVE BODY**  
 THIS IS TO CERTIFY THAT WE, THE CITY COUNCIL OF NORTH OGDEN CITY, WEBER COUNTY, UTAH HAVE RECEIVED A PETITION SIGNED BY A MAJORITY OF THE OWNERS AND THE OWNERS OF AT LEAST ONE THIRD IN VALUE OF REAL PROPERTY SHOWN, REQUESTING THAT SAID AREAS BE ANNEXED TO THE CITY OF NORTH OGDEN, UTAH AND THAT A COPY OF THE ORDINANCE OR RESOLUTION HAS BEEN PREPARED FOR FILING HEREWITH IN ACCORDANCE WITH THE PROVISIONS OF UTAH CODE ANNOTATED SEC. 10-2-425 AND THAT WE HAVE EXAMINED AND DO HEREBY APPROVE AND ACCEPT THE ANNEXATION OF THE AREAS AS SHOWN ON THIS FINAL LOCAL ENTITY PLAT AS A PART OF SAID CITY.

WITNESS MY HAND AND OFFICIAL SEAL THIS \_\_\_\_\_ DAY OF \_\_\_\_\_, 2012.

APPROVED: \_\_\_\_\_ MAYOR \_\_\_\_\_ CITY RECORDER

**ANNEXATION PLAT**  
**ORDINANCE NO. \_\_\_\_\_**  
 PLAT OF ADDITION TO  
 THE CORPORATE LIMITS OF  
**NORTH OGDEN CITY WEBER COUNTY, UTAH**  
 JULY, 2012  
 A PART OF THE NORTHEAST QUARTER AND THE  
 SOUTHEAST QUARTER OF SECTION 27,  
 TOWNSHIP 7 NORTH, RANGE 1 WEST,  
 SALT LAKE BASE AND MERIDIAN, U.S. SURVEY.

**WEBER COUNTY SURVEYOR**  
 THIS PLAT IS HEREBY APPROVED AS A FINAL LOCAL ENTITY PLAT AS REQUIRED BY UTAH CODE 17-23-20.  
 SIGNED THIS \_\_\_\_\_ DAY OF \_\_\_\_\_, 2012.  
 \_\_\_\_\_  
 WEBER COUNTY SURVEYOR

**WEBER COUNTY RECORDER**  
 Entry No. \_\_\_\_\_  
 Fee Paid: \_\_\_\_\_  
 Filed for Record and Recorded: \_\_\_\_\_ 2012.  
 At \_\_\_\_\_ In Book \_\_\_\_\_ of the Official Records,  
 Page \_\_\_\_\_  
 Recorded For: \_\_\_\_\_ TIME: \_\_\_\_\_  
 \_\_\_\_\_  
 Weber County Recorder  
 Deputy

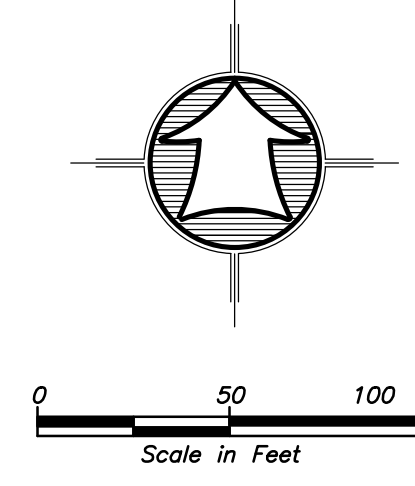

- LEGEND:**
- SUBJECT PROPERTY LINE
  - ADJOINER PROPERTY LINE
  - CENTERLINE
  - FENCE LINE
  - ◆ SECTION CORNER
  - ▨ EXISTING CITY LIMITS
  - ▩ PROPOSED CORPORATE BOUNDARY
  - SET 5/8" REBAR W/ CAP
  - FOUND REBAR AND CAP

**HAI** HANSEN & ASSOCIATES, INC.  
 Consulting Engineers and Land Surveyors  
 538 North Main Street, Brigham, Utah 84302  
 www.haies.net  
 Brigham City Ogden Logan  
 (435) 723-3491 (801) 399-4905 (435) 752-6272

N:\2012\12-111.mxd 12-111.dwg 06/13/12 8:09:55 AM